

RACAL INSTRUMENTS
1260-152HV
1260-172HV
HIGH VOLTAGE PLUG-IN

PUBLICATION NO. 980824-152/72HV

EADS North America Defense Test and Services, Inc.
4 Goodyear, Irvine, CA 92618
Tel: (800) 722-2528, (949) 859-8999; Fax: (949) 859-7139

info@eads-nadefense.com
sales@eads-nadefense.com
helpdesk@eads-nadefense.com
<http://www.eads-nadefense.com>



PUBLICATION DATE: August 05, 2003

Copyright 2000 by EADS North America Defense Test and Services, Inc. Printed in the United States of America. All rights reserved. This book or parts thereof may not be reproduced in any form without written permission of the publisher.

**THANK YOU FOR PURCHASING THIS
EADS NORTH AMERICA DEFENSE TEST AND SERVICES PRODUCT**

For this product, or any other EADS North America Defense Test and Services, Inc. product that incorporates software drivers, you may access our web site to verify and/or download the latest driver versions. The web address for driver downloads is:

<http://www.eads-nadefense.com/downloads>

If you have any questions about software driver downloads or our privacy policy, please contact us at

info@eads-nadefense.com

WARRANTY STATEMENT

All EADS North America Defense Test and Services, Inc. products are designed and manufactured to exacting standards and in full conformance to EADS ISO 9001:2000 processes.

This warranty does not apply to defects resulting from any modification(s) of any product or part without EADS North America Defense Test and Services, Inc. express written consent, or misuse of any product or part. The warranty also does not apply to fuses, software, non-rechargeable batteries, damage from battery leakage, or problems arising from normal wear, such as mechanical relay life, or failure to follow instructions.

This warranty is in lieu of all other warranties, expressed or implied, including any implied warranty of merchantability or fitness for a particular use. The remedies provided herein are buyer's sole and exclusive remedies.

For the specific terms of your standard warranty, or optional extended warranty or service agreement, contact your EADS North America Defense Test and Services, Inc. customer service advisor. Please have the following information available to facilitate service.

1. Product serial number
2. Product model number
3. Your company and contact information

You may contact your customer service advisor by:

E-Mail:	Helpdesk@eads-nadefense.com	
Telephone:	+1 800 722 3262	(USA)
Fax:	+1 949 859 7309	(USA)

RETURN of PRODUCT

Authorization is required from EADS North America Defense Test and Services, Inc. before you send us your product for service or calibration. Call or contact the Customer Support Department at 1-800-722-3262 or 1-949-859-8999 or via fax at 1-949-859-7139. We can be reached at: helpdesk@eads-nadefense.com.

PROPRIETARY NOTICE

This document and the technical data herein disclosed, are proprietary to EADS North America Defense Test and Services, Inc., and shall not, without express written permission of EADS North America Defense Test and Services, Inc., be used, in whole or in part to solicit quotations from a competitive source or used for manufacture by anyone other than EADS North America Defense Test and Services, Inc. The information herein has been developed at private expense, and may only be used for operation and maintenance reference purposes or for purposes of engineering evaluation and incorporation into technical specifications and other documents which specify procurement of products from EADS North America Defense Test and Services, Inc.

DISCLAIMER

Buyer acknowledges and agrees that it is responsible for the operation of the goods purchased and should ensure that they are used properly and in accordance with this handbook and any other instructions provided by Seller. EADS North America Defense Test and Services, Inc. products are not specifically designed, manufactured or intended to be used as parts, assemblies or components in planning, construction, maintenance or operation of a nuclear facility, or in life support or safety critical applications in which the failure of the EADS North America Defense Test and Services, Inc. product could create a situation where personal injury or death could occur. Should Buyer purchase EADS North America Defense Test and Services, Inc. product for such unintended application, Buyer shall indemnify and hold EADS North America Defense Test and Services, Inc., its officers, employees, subsidiaries, affiliates and distributors harmless against all claims arising out of a claim for personal injury or death associated with such unintended use.

FOR YOUR SAFETY

Before undertaking any troubleshooting, maintenance or exploratory procedure, read carefully the **WARNINGS** and **CAUTION** notices.



CAUTION
RISK OF ELECTRICAL SHOCK
DO NOT OPEN



This equipment contains voltage hazardous to human life and safety, and is capable of inflicting personal injury.



If this instrument is to be powered from the AC line (mains) through an autotransformer, ensure the common connector is connected to the neutral (earth pole) of the power supply.



Before operating the unit, ensure the conductor (green wire) is connected to the ground (earth) conductor of the power outlet. Do not use a two-conductor extension cord or a three-prong/two-prong adapter. This will defeat the protective feature of the third conductor in the power cord.



Maintenance and calibration procedures sometimes call for operation of the unit with power applied and protective covers removed. Read the procedures and heed warnings to avoid “live” circuit points.

Before operating this instrument:

1. Ensure the proper fuse is in place for the power source to operate.
2. Ensure all other devices connected to or in proximity to this instrument are properly grounded or connected to the protective third-wire earth ground.

If the instrument:

- fails to operate satisfactorily
- shows visible damage
- has been stored under unfavorable conditions
- has sustained stress

Do not operate until, performance is checked by qualified personnel.

Racal Instruments

EC Declaration of Conformity

We

Racal Instruments Inc.
4 Goodyear Street
Irvine, CA 92718

declare under sole responsibility that the

**1260-152HV, 1260-172HV
High Voltage Coaxial Switch Modules
407742-001, 407742-002**

conform to the following Product Specifications:

Safety: EN 61010-1

EMC: EN50081-1
CISPR 11:1990/EN 55011 (1991): Group 1 Class A
IEC 801-2:1991/EN 50082-1 (1992): 4 kV CD, 8 kV AD
IEC 801-3:1984/EN 50082-1 (1992): 3 V/m, 27-500 MHz
IEC 801-4:1988/EN 50082-1 (1992): 1 kV

Supplementary Information:

The above specifications are met when the product is installed in a Racal Instruments Adapt-a-Switch Carrier with faceplates installed over all unused slots, as applicable. The carrier is installed in a certified mainframe.

The product herewith complies with the requirements of the Low Voltage Directive 73/23/EEC and the EMC Directive 89/336/EEC.

Irvine, CA, December 6, 2000

Quality Manager

This page was left intentionally blank.

Table of Contents

Chapter 1	1-1
SPECIFICATIONS	1-1
Introduction.....	1-1
Specifications	1-2
Power Dissipation.....	1-3
About MTBF	1-4
Ordering Information	1-5
Chapter 2	2-1
INSTALLATION INSTRUCTIONS	2-1
Unpacking and Inspection	2-1
Reshipment Instructions.....	2-2
Installation	2-2
Module Configurations	2-3
Front Panel Connectors.....	2-3
Mating Connectors.....	2-5
Chapter 3	3-1
MODULE OPERATION	3-1
Setting the Module Address	3-1
1256 Operation.....	3-1
VXI Operating Modes	3-1

Operating In VXI Message-Based Mode.....3-3

 Channel Descriptors For The 1260-152HV/172HV3-3

 Reply To The MOD:LIST? Command.....3-4

Operating in VXI Register-Based Mode3-4

 1260-152HV/172HV Example Code3-8

Chapter 44-1

OPTIONAL ASSEMBLIES4-1

Chapter 55-1

PRODUCT SUPPORT5-1

 Product Support5-1

 Warranty.....5-1

List of Figures

Figure 1-1, 1260-152HV/172HV	1-1
Figure 2-1, Front-Panel Connector Pin Numbering	2-3
Figure 2-2, Relay Diagram.....	2-4
Figure 2-3, Block Diagram	2-5
Figure 3-1, Message-Based Mode of Operation.....	3-2
Figure 3-2, Register-Based Mode of Operation.....	3-2

List of Tables

Table 2-1, 1260-152HV/172HV Front-Panel Connections.....	2-4
Table 3-1, Control Register Channel Assignments.....	3-6

This page was left intentionally blank.

Chapter 1

SPECIFICATIONS

Introduction

The 1260-152HV/172HV is a plug-in switch module developed for the 1260-100 Adapt-a-Switch Carrier and the 1256 Switch Controller. The 1260-152HV/172HV includes the following features:

- Standard plug-in design, providing for ease of replacement.
- Data-Driven embedded descriptor, allowing immediate use with any Option-01T or 1256 switch controller, regardless of firmware revision level.
- 20 High-Voltage channels of SPST switching.
- 2 additional High-Voltage channels of 1x2 Mux switching.

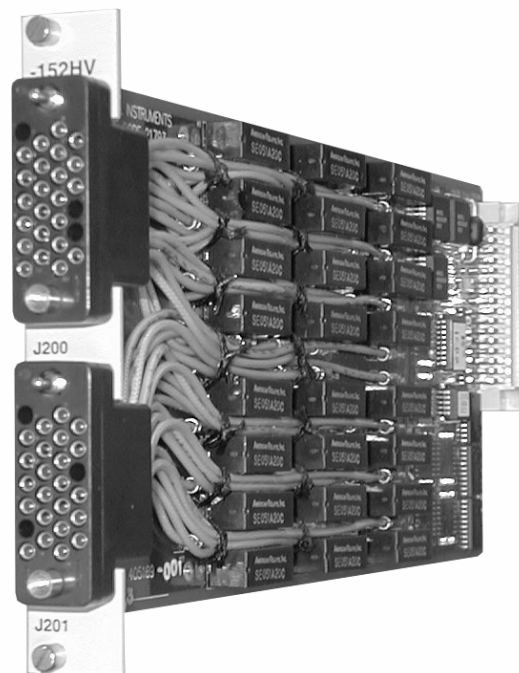

Figure 1-1, 1260-152HV/172HV

Specifications

Characteristic Impedance	
1260-152HV	50 Ω
1260-172HV	75 Ω
Bandwidth (-3dB)	> 500 MHz
Insertion Loss	
300 KHz	< 0.2 dB
100 MHz	< 0.5 dB
Return Loss	
100 MHz	> 15 dB
VSWR	
100 MHz	< 1.4:1
Isolation	
100 MHz	> 35 dB
Crosstalk	
100 MHz	< -45 dB
Maximum Switching Voltage	
AC	500 VAC peak
DC	500 VDC
Switching Current	
AC	0.50 AAC peak
DC	0.50 A
Switching Power	
AC	10 VA
DC	10 W
Path resistance	< 1 Ω
Capacitance	
Channel-Ground	< 60 pF
Open-Channel	< 5 pF
Insulation resistance	> 10 ⁹ Ω
Relay Settling Time	< 5 ms
Shock	30g, 11 ms, ½ sine wave
Vibration	0.013 in. P _k -P _k , 5-55 Hz
Bench Handling	4 in., 45°

Cooling	See 1260-100 cooling data
Temperature	
Operating	0°C to +55°C
Non-operating	-40°C to +75°C
Relative Humidity	85% ± 5% non-condensing at < 30°C
Altitude	
Operating	10,000 feet
Non-operating	15,000 feet
Power Requirements	
+5 VDC	150mA + 25mA per energized relay (0.8A Max.)
Weight	8 oz. (0.23 kg)
MTBF	> 300,000 hours (MIL-HDBK-217E)
Dimensions	4.5"H X 0.75"W X 9.5"D

Power Dissipation

While the cooling of the Adapt-a-Switch carrier is dependent upon the chassis into which it is installed, the carrier can normally dissipate approximately 100 W. Care must be taken, then, in the selection and loading of the plug-in modules used in the carrier. It is not possible to fully load the carrier, energize every relay, and run full power through every set of contacts, all at the same time. In practice this situation would never occur.

To properly evaluate the power dissipation of the plug-in modules, examine the path resistance, the current passing through the relay contacts, the ambient temperature, and the number of relays closed at any one time.

For example, if a 1260-152HV/172HV module (containing 24 relays) has all relays closed, passing a current of 0.5A, then:

$$\text{Total power dissipation} = [(\text{current})^2 * (\text{path resistance}) * 24] + (\text{quiescent power})$$

By substituting the actual values:

$$\text{Total power dissipation} = [(0.5 \text{ A})^2 * (1 \Omega) * 24] + (0.4 \text{ W}) = 6.4 \text{ W at } 55^\circ\text{C}$$

This is acceptable power dissipation for an individual plug-in module. If five additional modules are likewise loaded, then the overall carrier dissipation is approximately 38 W, which is well within the cooling available in any commercial VXIbus chassis. In

practice, rarely are more than 25% of the module's relays energized simultaneously, and rarely is full rated current run through every path. In addition, the actual contact resistance is typically one-half to one-fourth the specified maximum, and temperatures are normally not at the rated maximum. The power dissipated by each plug-in should be no more than 15 W if all six slots are used simultaneously. Consult the Power Dissipation Section of any other 1260 Adapt-a-Switch card manuals for additional information.

Most users of a signal-type switch, such as the 1260-152HV/172HV, switch no more than a few hundred milliamperes and are able to energize all relays simultaneously, should they so desire.

Additionally, if fewer plug-in modules are used, more power may be dissipated by the remaining cards. By using a chassis with high cooling capacity, such as the 1261B, almost any configuration may be realized.

About MTBF

The 1260-152HV/172HV MTBF is >300,000 hours, calculated in accordance with MIL-HDBK-217E, with the exception of the electromechanical relays. Relays are excluded from this calculation because relay life is strongly dependent upon operating conditions. Factors affecting relay life expectancy are:

1. Switched voltage
2. Switched current
3. Switched power
4. Maximum switching capacity
5. Maximum rated carrying current
6. Load type (resistive, inductive, capacitive)
7. Switching repetition rate
8. Ambient temperature

The most important factor is the maximum switching capacity, which is an interrelationship of maximum switching power, maximum switching voltage and maximum switching current. When a relay operates at a lower percentage of its maximum switching capacity, its life expectancy is longer. The maximum switching capacity specification is based on a resistive load, and must be further de-rated for inductive and capacitive loads.

For more details about the above life expectancy factors, refer to the data sheet for the switch plug-in module.

The relay used on the 1260-152HV/172HV plug-in is P/N 310282. The manufacturer's specifications for this relay are:

Life Expectancy	
Mechanical	100,000,000 operations
Electrical	100,000 operations at full rated load (resistive)

For additional relay specifications, refer to the relay manufacturer's data sheet.

Ordering Information

Listed below are part numbers for both the 1260-152HV/172HV switch modules and available mating connector accessories. Each 1260-152HV/172HV uses two mating connectors.

ITEM	DESCRIPTION	PART #
1260-152HV Switch Module	50Ω Coax Switch Module	407742-001
1260-172HV Switch Module	75Ω Coax Switch Module	407742-002
Shipping Kit	Mating connectors (2) and manual	407653-152/72HV
Mating Connector	26 Pin Housing	602221-126
Coax Pin	Pins	602221-903
Cable Assy. 2ft, 50Ω	Single Coax Cable w/connectors	407746-001
Cable Assy. 6ft, 50Ω	Single Coax Cable w/connectors	407746-003
Cable Assy. 12ft, 50Ω	Single Coax Cable w/connectors	407746-006
Cable Assy. 2ft, 75Ω	Single Coax Cable w/connectors	407747-001
Cable Assy. 6ft, 75Ω	Single Coax Cable w/connectors	407747-003
Cable Assy. 12ft, 75Ω	Single Coax Cable w/connectors	407747-006
Additional Manual	User Manual	980824-152/72HV

This page was left intentionally left blank.

INSTALLATION INSTRUCTIONS

Unpacking and Inspection



1. Remove the 1260-152HV/172HV module and inspect it for damage. If any damage is apparent, inform the carrier immediately. Retain shipping carton and packing material for the carrier's inspection.

CAUTION:

ESD sensitive devices, open the instrument at an ESD safe work station.

WARNING:

The 1260-152HV/172HV card is a high-voltage switch card. This card if improperly used could expose the user to potentially lethal voltages. Make absolutely sure, that all external high-voltage sources are off and locked-out prior to inserting, removing, or servicing this card in the chassis. The card retention screws should be tightened to the chassis and all chassis grounds should be verified with a ohmmeter prior to the first use. Failure to observe these precautions could result in either death or serious injury.

WARNING:

Extreme care must be exercised when high-voltage/high current power sources are used. Make sure that adequate external fault protection exists between these sources and the 1260-152HV/172HV. Failure to observe this precaution could result in fire or serious damage to both the 1260-152HV/172HV and chassis.

WARNING:

The 1260-152HV/172HV module should be periodically inspected for dust accumulation and removed as necessary to prevent internal arcing within the module.

CAUTION:

With reactive loads the 1260-152HV/172HV module should be switched with the high-voltage removed to eliminate the possibility of contact welding.

2. Verify that the pieces in the package you received contain the correct 1260-152HV/172HV module option and the 1260-152HV/172HV Users Manual. Notify EADS North America Defense Test and Services, Inc. if the module appears damaged in any way. Do not attempt to install a damaged module into a VXI chassis.
3. The 1260-152HV/172HV module is shipped in an anti-static bag to prevent electrostatic damage to the module. Do not remove the module from the anti-static bag unless it is in a static-controlled area.

Reshipment Instructions

1. Use the original packing when returning the switching module to EADS North America Defense Test and Services, Inc. for calibration or servicing. The original shipping carton and the instrument's plastic foam will provide the necessary support for safe reshipment.
2. If the original packing material is unavailable, wrap the switching module in an ESD Shielding bag and use plastic spray foam to surround and protect the instrument.
3. Reship in either the original or a new shipping carton.

Installation

Installation of the 1260-152HV/172HV Switching Module into a 1260-100 Carrier assembly is described in the Installation section of the 1260-100 Adapt-a-Switch Carrier Manual.

Module Configurations

The 1260-152HV and the 1260-172HV are high voltage coaxial switch modules each containing 20 channels of SPST (single-pole single-throw) switches and 2 channels of SPDT (single-pole double-throw) switching. The 1260-152HV uses 50 Ω coaxial cable and the 1260-172HV uses 75 Ω coaxial cable. Otherwise, the two modules are functionally equivalent.

Front Panel Connectors

The 1260-152HV/172HV has two 26-pin front-panel connectors, labeled J200 and J201. It is a 26-pin, MIL-DTL-28748 style, with shielded coaxial pins. See **Figure 2-1** for pin numbering. **Table 2-1** shows the mapping of channel numbers to connector pins. Information about available mating connectors is provided immediately after **Table 2-1**. See **Figure 2-2** for a detail of the actual relay. See **Figure 2-3** for a block diagram of the 1260-152HV/172HV.

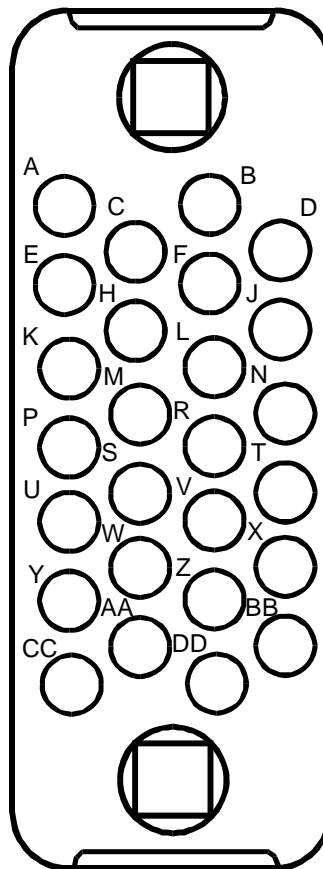

Figure 2-1, Front-Panel Connector Pin Numbering

Table 2-1, 1260-152HV/172HV Front-Panel Connections

Channel Number	In	Out
0	J200-E	J200-H
1	J200-K	J200-M
2	J200-P	J200-S
3	J200-U	J200-W
4	J200-C	J200-F
5	J200-L	J200-R
6	J200-V	J200-Z
7	J200-AA	J200-CC
8	J200-B	J200-D
9	J200-J	J200-N
10	J201-E	J201-H
11	J201-K	J201-M
12	J201-P	J201-S
13	J201-U	J201-W
14	J201-C	J201-F
15	J201-L	J201-R
16	J201-V	J201-Z
17	J201-AA	J201-CC
18	J201-T	J201-X
19	J201-BB	J201-DD
20	J200Y	J200-BB
21	J200Y	J200-DD
22	J201D	J201-B
23	J201D	J201-J

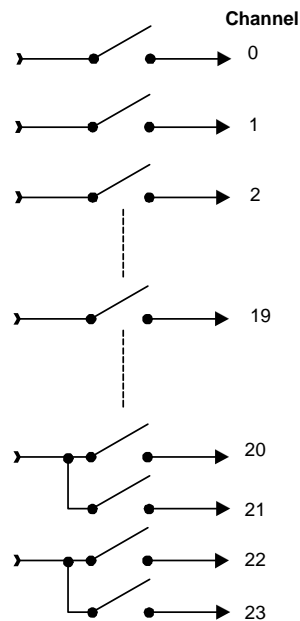

Figure 2-2, Relay Diagram

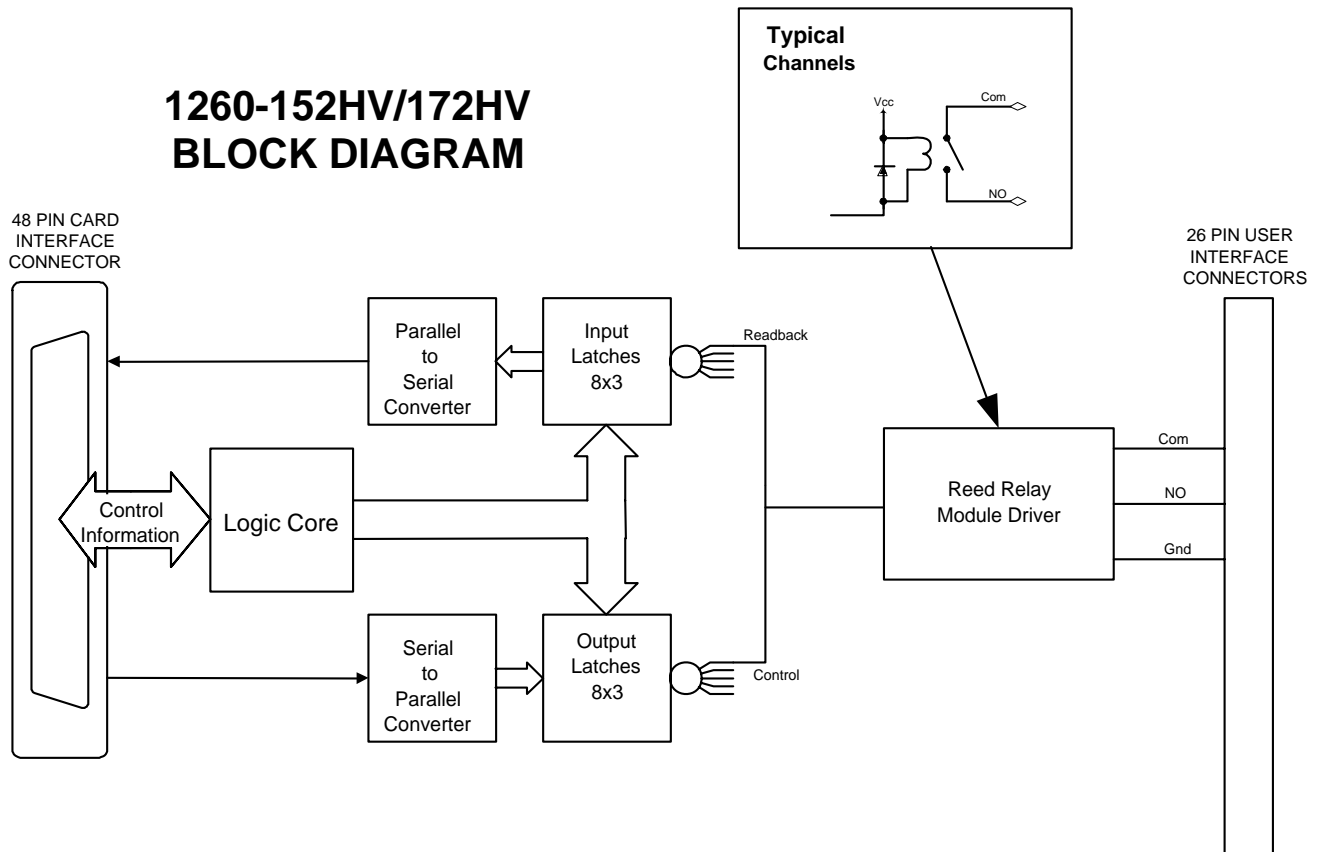

Figure 2-3, Block Diagram

Mating Connectors

Mating connector accessories are available:

26-Pin Connector, P/N 602221-126 and pins,
P/N 602221-903

The 26 pin connectors are provided as part of the 1260-152HV/172HV Shipping Kit. Mating Pins or Cable assemblies must be ordered separately. Refer to the Ordering Information section of this manual.

If mating pins are used, the suggested hand tool for the Crimp Pins is P/N 991034. After cable attachment, the pin is inserted into the housing and will snap into place, providing positive retention. The corresponding pin removal tool is P/N 990922.

This page was left intentionally blank.

Chapter 3

MODULE OPERATION

Setting the Module Address

Both the Option-01T and 1256 switch controllers identify each Adapt-a-Switch plug-in by a *module address* that is unique to that module.

For setting the module address of the 1260-152HV and 1260-172HV refer to one of the following manuals.

- 1260-100 Adapt-a-Switch Manual – Publication No. 980824-100
- 1256 User Manual – Publication No. 980855

1256 Operation

For a detailed description of the use of the 1260-152HV and 1260-172HV when they are being used in a 1256 Switch Controller, refer to the 1256 User Manual (P/N 980855).

VXI Operating Modes

The 1260-152HV/172HV may be operated either in *message-based* mode or in *register-based* mode when used with an Adapt-a-switch Carrier in a VXI chassis.

In the *message-based* mode, the 1260-01T switch controller interprets commands sent by the slot 0 controller, and determines the appropriate data to send to the control registers of the 1260-152HV/172HV module.

A conceptual view of the message-based mode of operation is shown in **Figure 3-1** below.

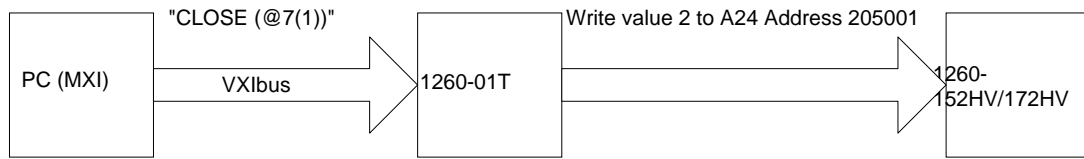

Figure 3-1, Message-Based Mode of Operation

In the *register-based* mode, the user writes directly to the control registers on the 1260-152HV/172HV module. The 1260-01T command module does not monitor these operations, and does not keep track of the relay states on the 1260-152HV/172HV module in this mode.

A conceptual view of the register-based mode is shown in **Figure 3-2** below.

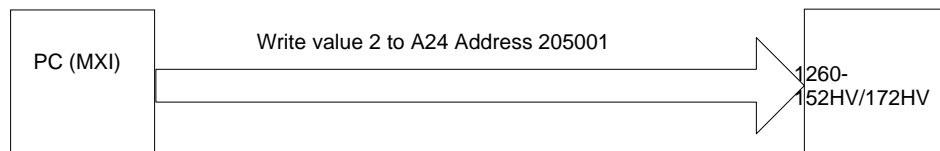

Figure 3-2, Register-Based Mode of Operation

Since the 1260-01T switch controller does not keep track of relay states during the register-based mode, it is advisable to use **either** the message-based or the register-based mode, and continue to use the same mode throughout the application program.

In general, the message-based mode of operation is easier to use with utility software such as the National Instruments VXI Interactive Control (VIC) program. The message-based mode allows the user to send ASCII text commands to the 1260-01T and to read replies from the 1260-01T. In addition, some features, such as the SCAN list, are available only in the message-based mode of operation.

The register-based mode provides faster control of relay channels. In this mode, relay operations are processed in less than 9 microseconds, not counting relay settling time or software overhead inherent in I/O libraries such as VISA. To determine the relay settling time, refer to Relay Settling Time in the Specifications section.

Consult the 1260-01T User's Manual for a comparison of the message-based and register-based modes of operation.

Operating In VXI Message-Based Mode

Channel Descriptors For The 1260-152HV/172HV

The standard 1260-01T commands are used to operate the 1260-152HV/172HV module. These commands are described in the 1260-01T User's Manual.

Each 1260-01T relay command uses a *channel descriptor* to select the channel(s) of interest. The syntax for a channel descriptor is the same for all 1260 series modules. In general, the following syntax is used to select a single channel:

```
(@ <module address> ( <channel> ) )
```

Where:

- <module address> is the address of the 1260-152HV/172HV module. This is a number in the range from 1 through 12, inclusive.
- <channel range> is a list of channels to operate. Each channel is a two-digit number. Thus, the valid channel numbers are:

0 through 23

Channels pairs 20/21, and 22/23 each share a common input.

When listing multiple channels, separate the channels with a comma (.). To select a contiguous range of channels, specify the first and last channels, and separate them by a colon (:)

The following examples illustrate the use of the channel descriptors for the 1260-152HV/172HV, with a module address of 8.

```
OPEN (@8(0))
```

Open channel 0.

OPEN (@8(10))	Open channel 10.
CLOSE (@8(9))	Close channel 9 on the 1260-152HV/172HV.
CLOSE (@8(11,23))	Close channels 11 and 23 on the 1260-152HV/172HV.
OPEN (@8(0:23))	Open channels 0 through 23 (all channels) on the 1260-152HV/172HV.
CLOSE (@8(0,10:22))	Close channels 0, 10, through 22 on the 1260-152HV/172HV.

Reply To The MOD:LIST? Command

The 1260-01T returns a reply to the MOD:LIST? command. This reply is unique for each different 1260 series switch module. The syntax for the reply is:

<module address> : <module-specific identification string>

The <module-specific identification string> for the 1260-152HV/172HV are:

```
1260-152HV HIGH VOLTAGE 50 OHM SWITCH
MODULE
```

or

```
1260-172HV HIGH VOLTAGE 75 OHM SWITCH
MODULE
```

So, for a 1260-152HV whose <module address> is set to 8, the reply to this query would be:

```
8 : 1260-152HV HIGH VOLTAGE 50 OHM SWITCH MODULE
```

Operating in VXI Register-Based Mode

In register-based mode, the 1260-152HV/172HV is operated by directly writing and reading control registers on the 1260-152HV/172HV module. The first control register on the module operates channels 0 through 7. The second control register operates channels 8 through 15. The third control register operates channels 16 through 23, etc. When a control register is written to, all channels controlled by that register are operated simultaneously.

The control registers are located in the VXIbus A24 Address Space. The A24 address for a control register depends on:

1. The A24 Address Offset assigned to the 1260-01T module by the Resource Manager program. The Resource Manager program is provided by the VXIbus slot-0 controller vendor. The A24 Address Offset is placed into the "Offset Register" of the 1260-01T by the Resource Manager.
2. The <module address> of the 1260-152HV/172HV module. This is a value in the range from 1 and 12 inclusive.
3. The 1260-152HV/172HV control register to be written to or read from. Each control register on the 1260-152HV/172HV has a unique address.

The base A24 address for the 1260-152HV/172HV module may be calculated by:

$$(\text{A24 Offset of the 1260-01T}) + (1024 \times \text{Module Address of 1260-152HV/172HV}).$$

The A24 address offset is usually expressed in hexadecimal. A typical value of 204000_{16} is used in the examples that follow.

A 1260-152HV/172HV with a module address of 7 would have the base A24 address computed as follows:

$$\text{Base A24 Address of 1260-152HV/172HV} = 204000_{16} + (400_{16} \times 7_{10}) = 205C00_{16}$$

The control registers for Adapt-a-Switch plug-ins and conventional 1260-Series modules are always on odd-numbered A24 addresses. The three control registers for the 1260-152HV/172HV reside at the first three odd-numbered A24 addresses for the module:

$$(\text{Base A24 Address of 1260-152HV/172HV}) + 1 = \text{Control Register 0}$$

$$(\text{Base A24 Address of 1260-152HV/172HV}) + 3 = \text{Control Register 1}$$

$$(\text{Base A24 Address of 1260-152HV/172HV}) + 5 = \text{Control Register 2}$$

So, for our example, the three control registers are located at:

205C01 Control Register 0, controls channels 0 through 7.

205C03 Control Register 1, controls channels 8

through 15.

205C05 Control Register 2, controls channels 16 through 23.

Table 3-1 shows the channel assignments for each control register.

Table 3-1, Control Register Channel Assignments

Control Register	Channels							
	Bit 7 (MSB)	Bit 6	Bit 5	Bit 4	Bit 3	Bit 2	Bit 1	Bit 0 (LSB)
0	7	6	5	4	3	2	1	0
1	15	14	13	12	11	10	9	8
2	23	22	21	20	19	18	17	16

Setting a control bit to 1 closes the corresponding channel, and clearing the bit to zero opens the corresponding channel. Thus, if you write the value 1000 0101 binary = 133 decimal = 85 hexadecimal to Control Register 0, channels 0, 2, and 7 will close, while channels 1, 3, 4, 5, and 6 will open.

The present control register value may be read back by reading an 8-bit value from the control register address. **The value is inverted.** In other words, the eight-bit value read back is the one's complement of the value written.

If you want to change the state of a single relay without affecting the present state of the other relays controlled by the control register, you must:

1. Read the control register.
2. Invert the bits (perform a one's complement on the register data).
3. Perform a bit-wise AND operation, leaving all but the specific control register bit for the relay to change.
4. **To open:** continue to step 5. **To close:** OR in the bit for the relay to close.
5. Write the modified value back to the control register.

For example, to close channel 13:

1. Read Control Register 1 (this register controls channels 8 through 15, with channel 8 represented by the LSB).
2. Invert the bits in the value read in step 1.
3. AND with 1101 1111 binary (the zero is in the position corresponding to channel 13).
4. OR with 0010 0000 binary.
5. Write the value to Control Register 1.

The VISA I/O library may be used to control the module. The VISA function `viOut8()` is used to write a single 8-bit byte to a control register, while `viIn8()` is used to read a single 8-bit byte from the control register. The following code example shows the use of `viOut8()` to update the 1260-152HV/172HV module.

1260- 152HV/172HV Example Code

```
#include <visa.h>

/* This example shows a 1260-01T at logical address 16 and a VXI/MXI */
/* interface */
#define RI1260_01_DESC      "VXI::16"

/* For a GPIB-VXI interface, and a logical address of 77 */
/* the descriptor would be: "GPIB-VXI::77" */

/* this example shows a 1260-152HV/172HV with module address 7 */
#define MOD_ADDR_152HV 7

void example_operate_1260_152HV(void)
{
    ViUInt8 creg_val;
    ViBusAddress creg0_addr;
    ViBusAddress creg1_addr;
    ViBusAddress creg2_addr;
    ViSession hdl1260;    /* VISA handle to the 1260-01T */
    ViSession hdlRM;     /* VISA handle to the resource manager */
    ViStatus error;      /* VISA error code */

    /* open the resource manager */
    /* this must be done once in application program */
    error = viOpenDefaultRM (&hdlRM);

    if (error < 0) {
        /* error handling code goes here */
    }

    /* get a handle for the 1260-01T */
    error = viOpen (hdlRM, RI1260_01_DESC, VI_NULL,VI_NULL, &hdl1260);
    if (error < 0) {
        /* error handling code goes here */
    }
}
```

```
/* form the offset for control register 0 */
/* note that the base A24 Address for the 1260-01T */
/* is already accounted for by VISA calls viIn8() and */
/* viOut8() */

    /* module address shifted 10 places = module address x 1024 */
    creg0_addr = (MOD_ADDR_152HV << 10) + 1;
    creg1_addr = creg0_addr + 2;
    creg2_addr = creg1_addr + 2;

/* close channel 13 without affecting the state of */
/* channels 8, 9, 10, 11, 12, 14, and 15 */
error = viIn8 (hdl1260, VI_A24_SPACE, creg1_addr, &creg_val);
if (error < 0) {
    /* error handling code goes here */
}

/* invert the bits to get the present control register value */
creg_val = ~creg_val;

/* AND to leave every channel except 13 unchanged */
creg_val &= ~ (0x20);

/* OR in the bit to close channel 13 */
creg_val |= 0x20;

/* write the updated control register value */
error = viOut8 (hdl1260, VI_A24_SPACE, creg1_addr, creg_val);
if (error < 0) {
    /* error handling code goes here */
}

/* open channel 16 without affecting channels 17 through 23 */
error = viIn8 (hdl1260, VI_A24_SPACE, creg2_addr, &creg_val);
if (error < 0) {
    /* error handling code goes here */
}

/* invert the bits to get the present control register value */
creg_val = ~creg_val;

/* AND to leave every channel except 16 unchanged */
/* leave bit 0 clear to open channel 16 */
creg_val &= ~ (0x01);

/* write the updated control register value */
error = viOut8 (hdl1260, VI_A24_SPACE, creg2_addr, creg_val);
```

```
if (error < 0) {
    /* error handling code goes here */
}

/* close the VISA session */
error = viClose( hdl1260 );
if (error < 0) {
    /* error handling code goes here */
}
}
```

Chapter 4

OPTIONAL ASSEMBLIES

407746-001	Cable Assy, 50Ω.....	4-3
407747-001	Cable Assy, 75Ω.....	4.5

This page was left intentionally blank.

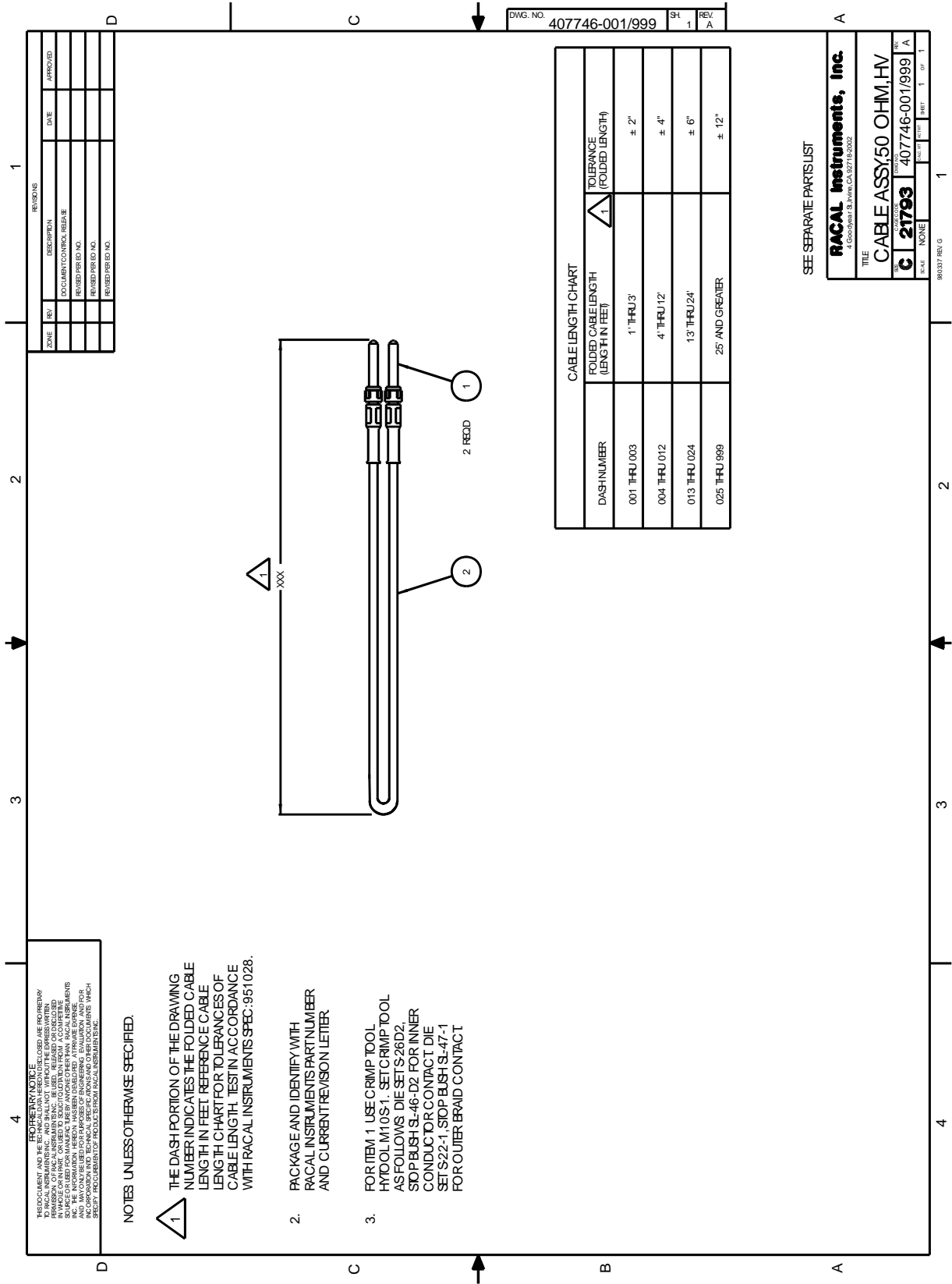

4

3

2

1

PROPRIETARY NOTICE
 THE DOCUMENT AND THE TECHNICAL DATA HEREBY INCLOSED ARE PROPRIETARY INFORMATION OF RACAL INSTRUMENTS INC. REPRODUCED, REPRODUCED OR DISCLOSED WITHOUT THE WRITTEN PERMISSION OF RACAL INSTRUMENTS INC. RACAL INSTRUMENTS INC. SOURCE CODED FOR MANUFACTURE BY ANOTHER COMPANY THAN RACAL INSTRUMENTS INC. THE INFORMATION HEREON HAS BEEN DEVELOPED AT PRIVATE EXPENSE FOR THE COMPONENTS AND TECHNICAL SPECIFICATIONS AND OTHER DOCUMENTS WHICH SPECIFY REQUIREMENTS OF PRODUCTS FROM RACAL INSTRUMENTS INC.

NOTES: UNLESS OTHERWISE SPECIFIED.

1 THE DASH PORTION OF THE DRAWING NUMBER INDICATES THE FOLDED CABLE LENGTH IN FEET, REFERENCE CABLE LENGTH CHART FOR TOLERANCES OF CABLE LENGTH. TEST IN ACCORDANCE WITH RACAL INSTRUMENTS SPEC:951075.

2. PACKAGE AND IDENTIFY WITH RACAL INSTRUMENTS PART NUMBER AND CURRENT REVISION LETTER.

3. FOR ITEM 1 USE CRIMP TOOL HYTOOL M10S-1, SET CRIMP TOOL AS FOLLOWS: DIE SET S-23D2, STOP BUSH SL-46-D2 FOR INNER CONDUCTOR CONTACT, DIE SET S-22-1, STOP BUSH SL-47-1 FOR OUTER BRAID CONTACT.

DWG. NO. 407747-001/999

SH. 1

REV. A

4

3

2

1

CABLE LENGTH CHART

DASH NUMBER	FOLDED CABLE LENGTH (LENGTH IN FEET)	TOLERANCE (FOLDED LENGTH)
001 THRU 003	1' THRU 3'	± 2"
004 THRU 012	4' THRU 12'	± 4"
013 THRU 024	13' THRU 24'	± 6"
025 THRU 999	25' AND GREATER	± 12"

SEE SEPARATE PARTS LIST

RACAL Instruments, Inc.
4600 Airport Blvd., Torrance, CA 90503

TITLE
CABLE ASSY.75 OHM,HV

REV. **C** PART NO. 407747-001/999

SCALE NONE

98037 REV.6

Chapter 5

PRODUCT SUPPORT

Product Support

EADS North America Defense Test and Services, Inc. has a complete Service and Parts Department. If you need technical assistance or should it be necessary to return your product for repair or calibration, call 1-800-722-3262. If parts are required to repair the product at your facility, call 1-949-859-8999 and ask for the Parts Department.

When sending your instrument in for repair, complete the form in the back of this manual.

For worldwide support and the office closest to your facility, refer to the website for the most complete information <http://www.eads-nadefense.com>.

Warranty

Use the original packing material when returning the 1260-152HV/172HV to EADS North America Defense Test and Services, Inc. for calibration or servicing. The original shipping container and associated packaging material will provide the necessary protection for safe reshipment.

If the original packing material is unavailable, contact EADS North America Defense Test and Services, Inc. Customer Service at 1-800-722-3262 for information.

REPAIR AND CALIBRATION REQUEST FORM

To allow us to better understand your repair requests, we suggest you use the following outline when calling and include a copy with your instrument to be sent to the EADS North America Defense Test and Service, Inc. Repair Facility.

Model _____ Serial No. _____ Date _____

Company Name _____ Purchase Order # _____

Billing Address _____
City _____

State/Province _____ Zip/Postal Code _____ Country _____

Shipping Address _____
City _____

State/Province _____ Zip/Postal Code _____ Country _____

Technical Contact _____ Phone Number () _____

Purchasing Contact _____ Phone Number () _____

1. Describe, in detail, the problem and symptoms you are having. Please include all set up details, such as input/output levels, frequencies, waveform details, etc.

2. If problem is occurring when unit is in remote, please list the program strings used and the controller type.

3. Please give any additional information you feel would be beneficial in facilitating a faster repair time (i.e., modifications, etc.)

4. Is calibration data required? Yes No (please circle one)

Call before shipping Ship instruments to nearest support office.
Note: We do not accept
"collect" shipments.